

DUAL WAFER KNIFE GATE VALVE



Only Premium Materials are used in valve construction.

FEATURES

- Long-wearing replaceable sleeves.
- Face-To-Face MSS SP81.
- Long lasting lubrication.
- Open body prevents gate damage during actuation.
- High strength stainless steel blade.
- Two coat epoxy paint.
- Manual or Automated actuators available.
- Metric & Imperial drilling available.
- Low maintenance requirements.
- Full-Port, Bi-Directional design at 16 Bar (240 Psi).
- Bellows and Stem cover for protection.
- Zinc coated hardware.
- Stuffing box with gland follower.
- No pressure drop across valve.
- Lightweight design for easy handling.
- No seat cavity where solids can collect and prevent full gate closure.
- Fluorocarbon coated gate to reduce friction and wear life to seats.
- Universal tower frame.
- Two piece body allows for easier rebuilds.

DUAL's Wafer Knife Gate Valve has been designed as a space saving option for slurry applications. The full port design allows the gate to be fully isolated by the sleeves in the open position. When the valve is closed the gate pushes between the sleeves ensuring a 100% Bi-Directional bubble tight seal and zero downstream leakage. Any solids that could potentially clog or jam the blade are purged out from between the sleeves to atmosphere through the bottom of the valve housing.

PRODUCT SPECIFICATION

SIZE RANGE: 2" - 24" (50mm - 600mm)

VALVE TYPE: Slurry Knife Gate

BODY STYLE: Narrow Body (wafer)
MSS-SP81 Face to Face

TEMPERATURE RANGE: 176°F (80°C)

PRESSURE RATING: Up to 240 Psi (16 Bar)

BODY MATERIAL: Cast Ductile iron, 2 coat epoxy painted or Stainless Steel

GATE MATERIAL: 17-4PH Stainless Steel, 316L Stainless Steel, 2205 Duplex Stainless Steel, 2507 Duplex Stainless Steel, C276 Hastelloy

GATE / BLADE: Coated with fluorocarbon coating

SLEEVE MATERIAL (replaceable): Gum Rubber, High- temp EPDM, Neoprene, Nitrile, Chlorobutyl

DUTY: Abrasive applications

HYDRO-STATIC TEST: 1.5 Times the rated pressure

TEST AND MATERIAL CERTIFICATES: Standard Quality Documents on request

CERTIFICATES:

ACTUATION

- Electric
- Gearbox
- Hydraulic
- Pneumatic
- Handwheel
- Choice of operation is based on valve size & pressure.

ACCESSORIES

- Limited Switches
- PTFE blade coating
- Various blade materials
- Gate safety guards
- Deflector cone
- Bottom splash guard & drain plate.

APPLICATIONS

- Mining and mineral processing.
- Power generation.
- Sand and gravel.
- Chemical and soda ash.
- Pulp and paper.
- Environmental and effluent.
- Dry feeds & Powders.
- Coal
- Alumina
- Phosphate
- General Industry



RUBBER SLEEVES

HOW THE SLEEVE WORKS

Matching rubber ring sleeves with siffener rings are placed in the valve housing to seal against the gate when the valve is closed and seal against each other when the valve is open. This tight seal contains the high internal line pressure. Double-seated design provides Bi-Directional flow and shut-off.

DIMENSIONS AND WEIGHTS

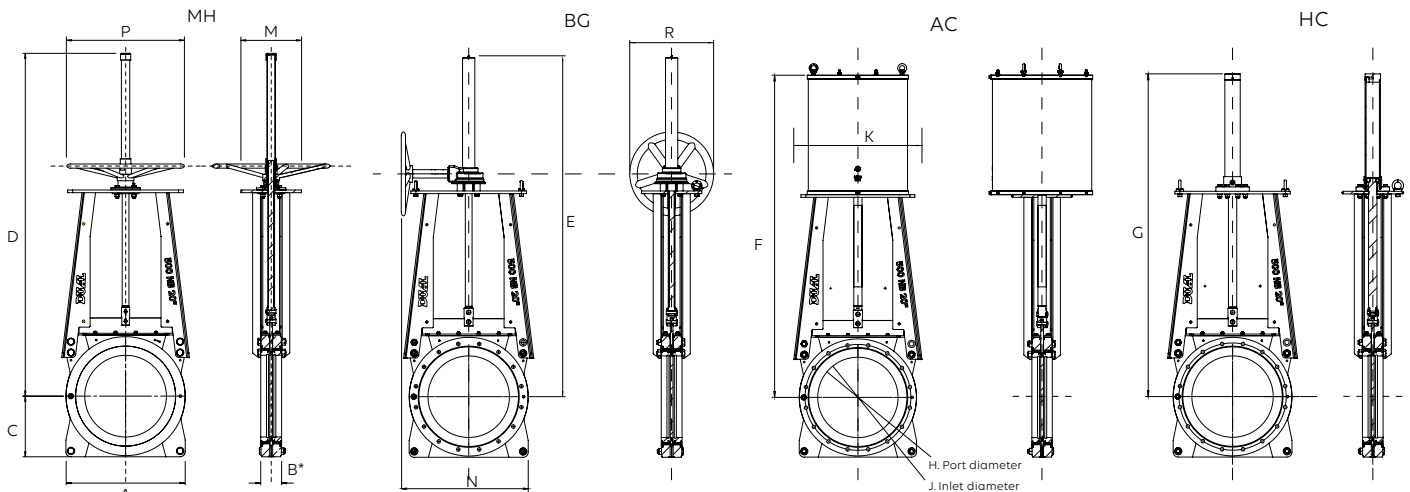

DIMENSIONS (mm)																	WEIGHT (kg)			
VALVE SIZE DN	A	B1*	B2*	C	D	E	F	G	H	J	K	M	N	P	R	MH	BG	AC	HC	
50	175	57	54	101	486	563	540	559	47	50	190	133	384	300	300	19	19	27	23	
80	203	62	57	124	567	611	627	640	71	76	222	162	400	300	300	24	24	37	30	
100	243	62	57	119	621	639	667	692	96	101	266	175	422	500	500	33	33	41	38	
150	279	68	63	146	748	838	803	825	147	152	320	231	449	500	500	39	39	64	42	
200	342	81	76	178	887	924	939	962	196	203	374	261	476	500	500	63	63	84	64	
250	416	82	76	209	1043	1125	1115	1137	247	254	444	339	606	500	500	87	87	145	100	
300	482	88	82	247	-	1207	1273	1289	297	304	517	341	738	600	600	166	166	220	141	
350	533	88	82	273	-	1340	1369	1372	329	336	572	374	765	600	600	195	195	292	168	
400	603	101	95	301	-	1435	1500	1503	381	387	621	374	790	600	600	234	234	328	238	
450	647	103	95	308	-	1680	1728	1737	431	438	668	431	768	700	700	253	253	374	283	
500	711	130	120	368	-	1823	1878	1882	483	489	712	479	790	700	700	325	325	519	335	
600	838	131	120	419	-	2162	2216	2235	589	595	889	479	878	700	700	468	468	719	513	

Contact Dual Valves for larger sizes. Dimensions and weights are for guidance only - detailed dimension drawings available on request. All dimensions are in millimeters, unless stated.



CORPORATE HEADQUARTERS:
166 ROTTERDAM ROAD
(CNR ROTTERDAM ROAD & ANTWERP STREET)
APEX BENONI GAUTENG SOUTH AFRICA

PO BOX 12520, BENORYN 1504
TEL: +27 11 422 4326/7
FAX: +27 11 421 7842
EMAIL: SALES@DUALVALVES.COM

