

DUAL SINGLE PINCH VALVE



FEATURES

- The Dual Single Pinch Valves double-ended enclosed body with easily replaceable, flexible rubber sleeves.
- Thrust bearing for ease of opening and closing (handwheel type).
 - Long operating life.
 - Full bore, low friction loss.
 - 100% drip tight closure even with solids in the medium.
 - Light weight.
 - Seals in both directions.
 - High flexibility sleeve design reduces closing forces, improves recovery to full open position.
 - Enclosed body protects the sleeve from the environment.
 - Fast and easy sleeve change.
 - Single wearing part.
 - Face to face compatible with diaphragm valves.
 - Rising and non rising spindle types.
 - Positive opening tags.
 - Open/closed sight glass indicator.
 - Visible spindle indicator.

DUAL's Single Pinch Valve consists of a tough, but flexible full bore sleeve, which forms part of the pipeline. The valve is closed mechanically via movement of a pinch gate located above the sleeve. The core of the Dual Single Pinch Valve is the sleeve. The valves are well suited for on/off and throttling control applications involving slurries, powders, liquids, granulated materials and applications where scale build is a problem.

FACE TO FACE COMPATIBLE WITH DIAPHRAGM VALVES

PRODUCT SPECIFICATION

- BODY:** Cast Aluminium, Cast SG Iron, Stainless Steel enclosed body type.
- ELASTOMER SLEEVE:** Gum Rubber, Red Rubber, EPDM, Butyl, Chlorobutyl, Neoprene, Polyurethane, Viton and Hypalon.
- SIZE RANGE:** 50mm - 350mm.
- PRESSURE RATING:** 10 Bar (For higher pressure consult factory).
- THRUST BEARINGS:** To reduce operating torque (handwheel type).
- FLANGED:** Drilled to SABS, ANSI BS or DIN.
- VALVE INTERVALS:** 304 Stainless Steel spindles and guides, rubber sleeve, steel Pinch Bars and Nylon Bushing.
- TEMPERATURE:** -50°C to 80°C.
- MATERIAL CERTIFICATION:** Certified chemical and physical test reports can be supplied.
- VALVE TYPE:** Rising and non rising spindle.

PNEUMATICALLY ACTUATED VALVE



DSPV

HOW THE VALVE OPERATES

As the valve cycles downwards, the Pinch Mechanism will start to compress the soft rubber sleeve, from the top of the valve only, therefore achieving a 100% drip tight closure, even with solids in the medium.

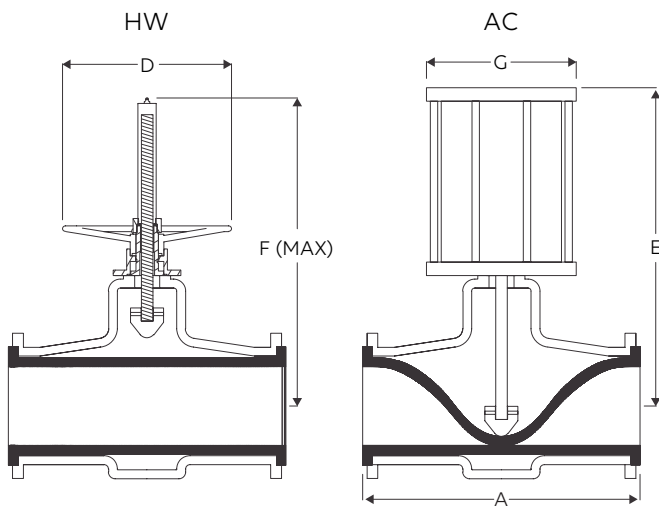
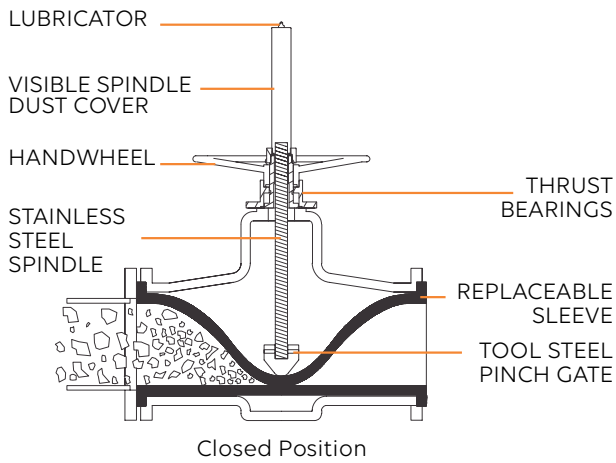

APPLICATIONS

- Mining and mineral processing.
- Power generation.
- Sand and gravel.
- Chemical and soda ash.
- Pulp and paper.

ACTUATORS

All types of actuators can be fitted, electric, gearbox, hydraulic, pneumatic or handwheel.

SLEEVE MATERIAL

Dual offers the following alternative sleeve materials, providing chemical and abrasive resistance to most media such as:

- Polyurethane.
- Natural Red Rubber.
- Natural Black Rubber.
- Neoprene Rubber.
- Nitrile Rubber.
- EPDM Rubber.
- Reduced port sleeve for throttling applications.



DIMENSIONS AND WEIGHTS

VALVE SIZE DN	A (mm)	B (mm)	C (mm)	D (mm)	E (mm)	F (mm)	G (mm)	WEIGHT (kg)	
								HW	AC
50	196	165	50	300	200	150	100	20	25
80	260	200	80	300	250	215	100	30	35
100	310	220	100	400	300	265	160	40	45
125	362	250	125	400	350	300	160	50	60
150	412	285	150	400	400	350	250	60	70
200	527	340	200	500	450	400	300	110	120
250	641	405	250	500	500	550	300	200	210
300	755	460	300	600	700	630	350	300	350
350	986	520	350	600	850	800	400	450	500

Dimensions and weights are for guidance only - detailed dimension drawings available on request. All dimensions are in millimeters, unless stated.



CORPORATE HEADQUARTERS:
166 ROTTERDAM ROAD
(CNR ROTTERDAM ROAD & ANTWERP STREET)
APEX BENONI GAUTENG SOUTH AFRICA

PO BOX 12520, BENORYN 1504
TEL: +27 11 422 4326/7
FAX: +27 11 421 7842
EMAIL: SALES@DUALVALVES.COM

