

### DUAL SEVERE SERVICE LINED KNIFE GATE VALVE



Zero discharge to atmosphere. Full round port design.

#### FEATURES

- Bi-Directional operation at 25 Bar/365 Psi.
- Superior Isolation.
- One piece peri-metal rubber seal (replaceable).
- No metal parts in contact with flowing slurry.
- Bubble tight shut off.
- External epoxy or powder coated.
- Easily adapted to fit most actuators.
- Low maintenance requirements.
- MSS-SP-81 Face-To-Face.
- Lock out and switch mountings.
- Live load packing gland.
- Full round port design and Bi-Directional.
- Lightweight material for easy handling.
- Replaceable Urethane or High Chrome liners.
- Robust gate design reduces bending.
- Zero discharge to atmosphere.
- No pressure drop across valve.
- PTFE blade wiper.
- Non-Rising spindle available.
- Fluoro-Carbon coated gate to reduce friction when stroked.
- Two piece wafer body.

**DUAL's** Severe Service Lined High-Pressure Knife Gate Valve is designed for full on/off applications. The valve features a robust peri-metal seal that provides a bubble tight shut off with replaceable Urethane or High Chrome liners. The liners are flush with the bottom of the valve, eliminating any pocket where material can collect, increasing reliability and service life. Full round port design and zero discharge to atmosphere.

#### PRODUCT SPECIFICATION

**SIZE RANGE:** 2" - 30" (50mm - 750mm)

**VALVE TYPE:** High-Pressure Slurry Knife Gate

**BODY STYLE:** Narrow Body (Wafer)  
MSS SP81 Face-to-Face

**TEMPERATURE RANGE:** -50°C - +80°C

**PRESSURE RATING:** Up to 300Psi (25 Bar)  
Higher pressure available (740Psi / 54 Bar)

**BODY MATERIAL:** Carbon Steel, 2 coat epoxy painted

**GATE MATERIAL:** Peri-metal Rubber seal with Replaceable Urethane or High Chrome liners.

**GATE / BLADE:** 17-4PH Stainless Steel, 316L Stainless Steel, 2205 Duplex Stainless Steel, 2507 Duplex Stainless Steel, C276 Hastelloy

**DUTY:** Abrasive applications

**HYDRO-STATIC TEST:** 1.5 Times the rated pressure

**COMPLIANCE TO:** MSS SP 81  
MSS SP 135  
ASME B31.3

**TEST AND MATERIAL DOCUMENTS:** Standard Quality Documents on request

**CERTIFICATES:**

DSSLKG

## ACTUATION

- Electric
- Gearbox
- Hydraulic
- Pneumatic
- Handwheel

## ACCESSORIES

- Limited Switches
- PTFE blade coating
- Various blade materials
- Gate safety guards
- Deflector cone
- Blade guard

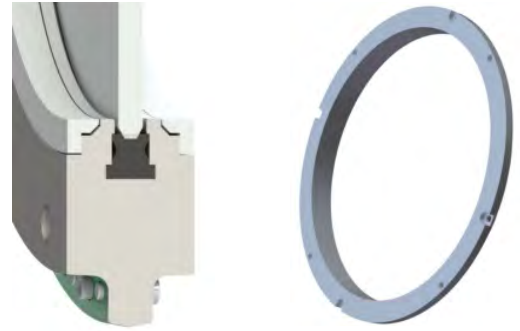

Robust, heavy cross-section seat provides superior isolation performance over the life of the valve, delivering higher cycle life at zero discharge.

Replaceable and Rotatable high-chrome wear rings, reducer wear on the valve and increase life cycle.

## APPLICATIONS

- Mining and mineral processing.
- Power generation.
- Sand and gravel.
- Chemical and soda ash.
- Pulp and paper.
- Environmental and effluent.
- Dry feeds & Powders

## HOW THE VALVE WORKS

The replaceable Urethane or High Chrome liner seat option, is flush with the bottom of the port, eliminating debris and slurry, allowing leak free closure and zero discharge to atmosphere.

## DIMENSIONS AND WEIGHTS

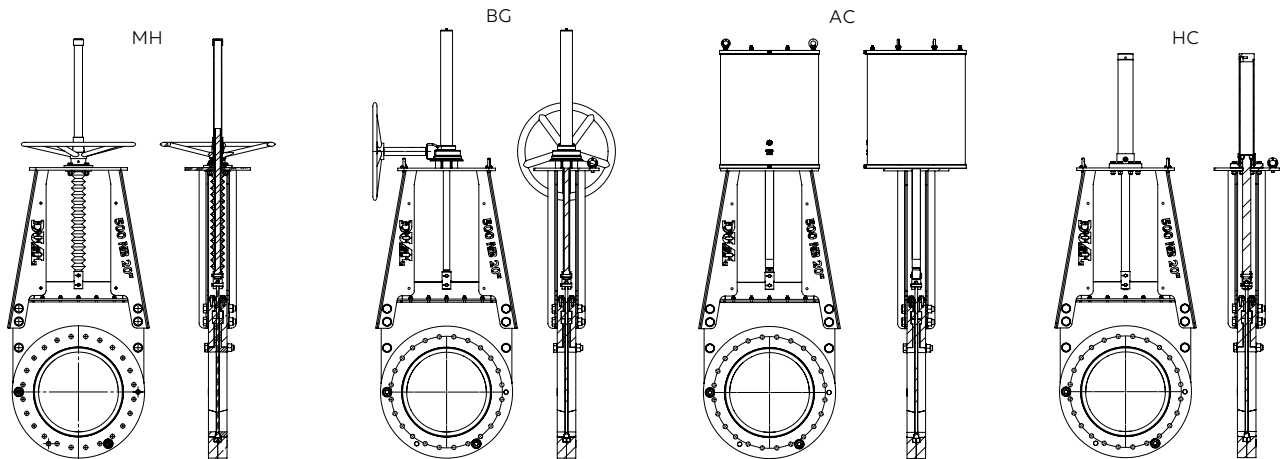

DIMENSIONS (mm)																	WEIGHT (kg)			
DN	ØA	ØB	C	C1	C2	C3	C4	D	E	ØF	ØF1	G	H	J	K	L	MH	BG	AC	HC
50	51	92	250	141	-	186	186	51	215	300	300	168	107	-	64	114	21	-	15	18
80	76	127	304	141	-	210	224	51	254	300	300	168	127	-	64	114	26	-	26	24
100	102	157	355	141	-	257	259	51	284	500	500	168	142	-	64	140	32	-	38	29
150	152	216	468	141	-	325	311	57	341	500	500	183	170	-	64	191	47	-	65	42
200	203	270	582	141	179	380	379	70	406	500	500	220	203	299	76	216	74	80	101	73
250	254	324	685	-	179	474	431	70	462	500	500	219	231	299	89	270	-	105	168	102
300	305	381	794	-	179	514	483	76	546	600	600	250	273	299	89	324	-	144	240	143
350	337	413	872	-	189	537	539	76	597	600	600	251	299	366	114	375	-	189	339	192
400	387	470	977	-	189	608	591	89	668	700	700	272	343	366	114	432	-	254	471	259
450	438	533	1108	-	189	676	656	89	723	700	700	302	362	366	127	483	-	363	649	382
500	489	584	1213	-	191	788	714	114	800	700	700	306	400	422	127	533	-	488	850	506
600	591	692	1448	-	221	950	836	114	943	700	700	368	472	460	165	635	-	757	1452	781
650	641	749	1576	-	221	1009	924	171	976	-	-	400	488	460	191	699	-	1006	1878	1065
700	692	800	1699	-	251	1061	976	181	1033	-	-	431	516	505	191	699	-	1205	2070	1256
750	743	857	1800	-	251	1136	1028	187	1097	-	-	461	548	505	191	756	-	1397	2625	1467

Contact Dual Valves for larger sizes. Dimensions and weights are for guidance only - detailed dimension drawings available on request. All dimensions are in millimeters, unless stated.



CORPORATE HEADQUARTERS:  
166 ROTTERDAM ROAD  
(CNR ROTTERDAM ROAD & ANTWERP STREET)  
APEX BENONI GAUTENG SOUTH AFRICA

PO BOX 12520, BENORYN 1504  
TEL: +27 11 422 4326/7  
FAX: +27 11 421 7842  
EMAIL: SALES@DUALVALVES.COM

