

### DUAL ROTARY DISC SLEEVE VALVE



#### FEATURES

- No pressure drop.
- No blocking or leakage.
- Disc can be replaced in situ.
- Low torque due to no gate guides.
- Long wear life (due to rotating gate/disc).
- Self cleaning gate action.
- Seals in both directions.
- Wedge for position seal.
- Cutaway to clean seating area.
- Fabricated valves can be repaired in line.
- Sleeve out of flow when in open position.
- Rising and non-rising spindle.
- Back seat to re-pack gland packing under pressure.
- Replaceable ring sleeve seat.
- Light weight.
- Spindle dust cover.
- Flush port.

**DUAL's** Rotary Disc Sleeve Valve is a unique rotating gate valve designed specifically for heavy abrasive and corrosive slurries. The Patented design allows the valve to cycle in heavy slurries without jamming and has a ring seat sleeve that can be replaced when worn. The valve can be used to control and throttle the flow.

#### PRODUCT SPECIFICATION

- VALVE BODY:** Fabricated Carbon Steel, Cast SG Iron, High Chrome or Stainless Steel.
- GATE MATERIAL:** Gate Material can be Carbon Steel, Abrasion Resistant Steel, Cast High Chrome or Stainless Steel.
- THICKNESS:** Gate to have a minimum safety factor of 2:1 based on yield strength of material.
- SHAPE:** Gate radius to be set for minimum valve height in chest area. Gate is Metal, Rubber or Urethane coated.
- REPLACEABLE RING SLEEVE:** Rubber or Urethane.
- THRUST BEARINGS:** To reduce operating torque (handwheel type).
- MATERIAL CERTIFICATION:** All vetted parts have certified chemical and physical test reports.
- TESTING:** All valves are tested per SABS specifications certified.
- PRESSURE RATING:** 10 Bar to 100 Bar (150 Psi to 1500 Psi).
- FLANGES:** Flanges comply with AS, ANSI, DIN, BS and SABS.
- FACE-TO-FACE:** To suit customer specifications.
- BODY LINING:** Rubber, Urethane or Ceramic.

#### VALVE OPERATION

As the handwheel is opening or closing, the disc rotates. This happens due to pressure pushing against the disc, causing the disc to touch the valve sleeve and rotate. As the valve is cycled, the disc rotates 100mm, seating in a different position each time. The valve body has a cutaway behind the disc clearing debris away and thus, ensuring the disc closes and seals.

## HOW THE SEAT SLEEVE WORKS

The ring seat sleeve with stiffener ring is placed in the valve housing to seal against the gate when the valve is in its closed position. When the valve is in the open position, the seat is out of the slurry flow, prolonging the life of the valve. The ring sleeve and gate are replaceable.

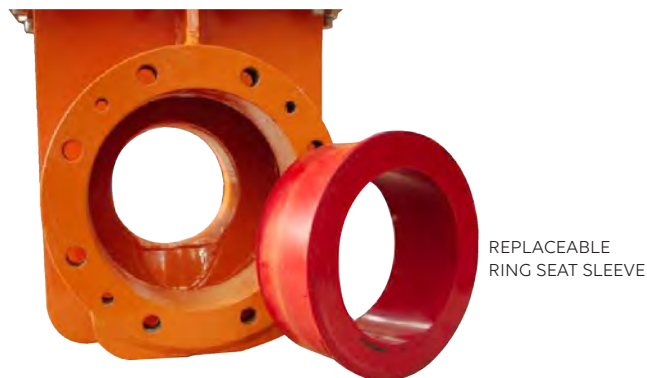

REPLACEABLE RING SEAT SLEEVE

## APPLICATIONS

- Mining and mineral processing.
- Power generation.
- Sand and gravel.
- Chemical and soda ash.
- Pulp and paper.
- Environmental and effluent.
- Water purification wastewater.

## ACCESSORIES

- Limit switches.
- Positioners.
- Deflection Cone.

	PART	DESCRIPTION
1	Body	Carbon, Cast SG Iron, Steel/Stainless Steel
2	Seat Sleeve	Rubber or Urethane
3	Disc	Stainless Steel or Other
4	Wedges	Mild Steel/Stainless Steel, Cast SG Iron
5	Bonnet	Mild Steel/Stainless Steel, Cast SG Iron
6	Packing	Graphite in Rope
7	Gland	S.S./Carbon Steel, Cast SG Iron
8	Spindle	Stainless Steel
9	Yoke Assembly	Mild Steel/Stainless Steel
10	Spindle Nut	Bronze
11	Handwheel	Cast SG Iron/Stainless Steel
12	Handwheel Nut	Carbon Steel/Stainless Steel
13	Body Lining	Rubber, Urethane or Ceramic

## ACTUATORS

All types of actuators can be fitted, electric, gearbox, hydraulic, pneumatic or handwheel.

## DIMENSIONS AND SPECIFICATIONS

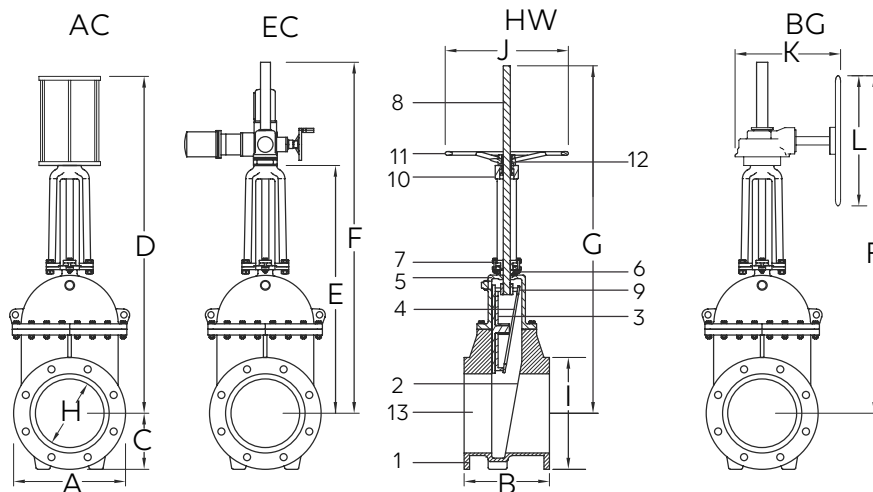

VALVE IN FULLY OPEN POSITION

VALVE SIZE (mm)	A	F/F B	C	AC D	EC E	BG F	HW G	H	I	J	K	L	WEIGHT (kg)
50 / 2"	170	216	85	559	300	370	550	50	170	300	350	300	50
80 / 3"	200	229	100	659	370	440	542	80	200	300	350	300	80
100 / 4"	220	254	110	710	380	470	695	100	220	400	350	400	90
150 / 6"	285	280	142	1003	610	661	900	150	285	500	350	400	90
200 / 8"	340	317	170	1224	770	845	1104	200	340	500	350	400	100
250 / 10"	405	356	202	1411	905	1014	1360	250	405	500	350	400	250
300 / 12"	460	380	230	1615	1012	1120	1560	300	460	500	350	400	300
350 / 14"	520	470	260	1745	1140	1230	1840	350	520	600	350	500	450
400 / 16"	580	470	290	2016	1280	1355	1940	400	580	600	350	500	500
450 / 18"	640	485	320	2300	1487	1600	2180	450	640	700	500	500	600
500 / 20"	720	510	360	2579	1690	1706	2350	500	720	700	500	500	720
600 / 24"	840	600	450	2750	1785	1885	2800	600	840	700	500	500	900

Contact Dual for larger sizes. Dimensions and weights are for guidance only - detailed dimension drawings available on request. All dimensions are in millimeters, unless stated.



CORPORATE HEADQUARTERS:  
166 ROTTERDAM ROAD  
(CNR ROTTERDAM ROAD & ANTWERP STREET)  
APEX BENONI GAUTENG SOUTH AFRICA

PO BOX 12520, BENORNYN 1504  
TEL: +27 11 422 4326/7  
FAX: +27 11 421 7842  
EMAIL: SALES@DUALVALVES.COM

