

DUAL PIVOT WAFER GATE VALVE



DUAL's Pivot Wafer Gate Valve is built with a steel body and features a heavy-duty stainless steel gate. Removable sleeves on either side of the gate provides a bi-directional bubble tight seal, with no metal parts in contact with the flowing slurry, when open. When the Dual Pivot Wafer Gate Valve closes, the gate valve moves through the Dual Ring Sleeves from the side, eliminating the damage to the sleeves.

FEATURES

- 240 Psi / 16 Bar.
- Double seat design for heavy duty slurry service.
- Ease of replacement of seat liners.
- When open, the gate is fully pivoted out of the slurry flow.
- No metal parts in contact with the flowing slurry.
- Bubble tight shutoff.
- No clogged bonnet to impede flow.
- External epoxy coated.
- Easily adapted to suit most actuators.
- Low maintenance requirements.
- Suitable for wet or dry service.
- Bi-directional flow.
- Gate guard.
- Rotary style movement of the gate.
- No gland to maintain.
- Wide range of elastomers available.

PRODUCT SPECIFICATION

BODY: Wafer pattern Cast SG Iron, Fabricated Steel, Epoxy coated.

ELASTOMER SLEEVES: Gum Rubber (standard), Nitrile, Viton, EPDM, Chlorobutyl or Urethane lined.

PRESSURE RATING: DN50 to DN600 rated to 240Psi (16 Bar).

GATE MATERIAL: 316 Stainless Steel standard - 316L, 317L, 17-4PH, Alloy 20, SAF 2205 S/S with optional wear coatings.

DRILLING PATTERNS: DN50 to DN600 drilled and tapped ASME B16.5, DIN, SABS & BS Optional.

MATERIAL CERTIFICATION: Certified chemical and physical test reports can be supplied.

RSA RegD. Design No. F2017/01372
RegD. Design No. A2017/01371
Patent No. 2017/05831

- Light weight for easier handling.
- No seat cavity where solids can collect and prevent full gate closure.
- Suitable for wet or dry service.
- Flush ports.
- Dual sleeve isolation.
- Face to face MSS-SP-81.

STANDARD FEATURES - VALVE BODY

- Protective bellows.
- Limit switch brackets.
- Open/closed indicator.
- Lubrication ports on both sides of the valve body.
- Splash guard with flush ports.
- Open/closed lockout.
- Adaptable tower design can be field modified to take air cylinder, gearbox or hydraulic actuators.

ACTUATORS

All types of actuators can be fitted, electric, gearbox, hydraulic, pneumatic or handwheel.

APPLICATIONS

- Mining and mineral processing.
- Power generation.
- Sand and gravel.
- Chemical and soda ash.
- Pulp and paper.
- Environmental and effluent.
- Water and wastewater.

HOW THE RUBBER SLEEVES WORK

Matching rubber ring sleeves with stiffener rings are placed in the valve housing to seal against the gate when the valve is closed and seal against each other when the valve is open. This tight seal contains the high internal line pressure. Double seated design provides bi-directional flow and shut off.



ACCESSORIES

- Limit switches.
- PTFE coating of gate.
- Various gate materials optional.
- Gate safety guards.

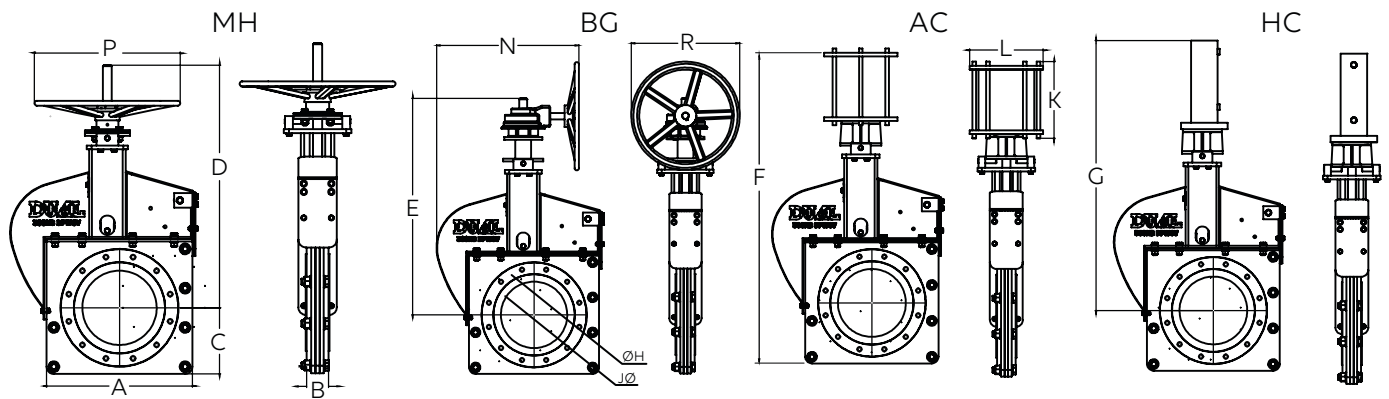

VALVE SIZE (mm)	A	B	C	D	E	F	G	H	J	K	L	AC kg	HC kg	MH kg	BG kg
50	59	54	197	511	44	489	300	483	300	-	-	65	52	43	50
80	64	57	232	593	73	568	300	559	300	564	324	84	70	55	60
100	64	57	273	661	98	645	300	620	300	649	324	95	85	75	80
150	70	64	340	818	149	940	300	777	300	810	371	145	100	90	90
200	83	76	397	960	198	1143	500	916	500	946	371	190	145	140	140
250	84	76	451	1106	248	1334	500	1068	500	1118	371	325	225	200	200
300	90	83	533	1302	299	1413	-	-	500	1321	425	493	320	375	350
350	90	83	581	1397	330	1562	-	-	600	1403	425	655	377	450	480
400	103	95	635	1562	381	1753	-	-	600	1549	425	736	535	525	525
450	105	95	686	1745	432	1753	-	-	600	1746	492	840	650	670	650
500	132	121	733	1930	483	1930	-	-	600	1927	492	1165	760	730	780
600	133	121	848	2199	587	2215	-	-	600	2213	492	1650	1120	1000	1200

Contact Dual for larger sizes. Dimensions and weights are for guidance only - detailed dimension drawings available on request. All dimensions are in millimeters, unless stated.



CORPORATE HEADQUARTERS:
166 ROTTERDAM ROAD
(CNR ROTTERDAM ROAD & ANTWERP STREET)
APEX BENONI GAUTENG SOUTH AFRICA

PO BOX 12520, BENORNYN 1504
TEL: +27 11 422 4326/7
FAX: +27 11 421 7842
EMAIL: SALES@DUALVALVES.COM

