

### DUAL PINCH VALVE ENCLOSED BODY TYPE



#### FEATURES

The Dual Pneumatic Pinch Valves double-enclosed body with easily replaceable, flexible rubber sleeves.

- Thrust bearing for ease of opening and closing (handwheel type).
- Long operating type.
- Full bore, low friction loss.
- 100% drip tight closure even with solids in the medium.
- Rising spindle.
- Seals in both directions.
- High flexibility sleeve design reduces closing forces, improves recovery to full open position.
- Enclosed body protects the sleeve.
- Fast and easy sleeve change.
- Single wearing part.
- Positive opening tags.
- Unobstructive flow reduces pumping costs.
- No glands which require regular adjustment.
- Available in open or enclosed body styles.

**DUAL's** Pinch Valve consists of a tough, but flexible full bore sleeve, which forms part of the pipeline. The valve is closed mechanically via movement of the Pinch Bars located on opposite sides of the sleeve. The core of the Dual Pinch Valve is the sleeve - this sleeve is reinforced with high-strength fabric. The valves are well suited for on/off and throttling control applications where scale build up is a problem.

#### FACE TO FACE COMPATIBLE WITH DIAPHRAGM VALVES

#### PRODUCT SPECIFICATION

- BODY:** Cast Iron/Aluminium or Fabricated Carbon Steel.
- ELASTOMER SLEEVE:** Gum Rubber, Red Rubber, EPDM, Butyl, Chlorobutyl, Neoprene, Polyurethane, Viton and Hypalon.
- SIZE RANGE:** 50mm - 350mm (For larger consult the factory).
- PRESSURE RATING:** 40 Bar (For higher pressure consult factory).
- PINCH BARS:** Carbon Steel Bar Stock.
- PINCH BAR GUIDES:** Stainless Steel with protective covers.
- FLANGED:** Drilled to SABS, ANSI BS or DIN.
- VALVE INTERVALS:** 304 Stainless Steel spindles and guides, rubber sleeve, steel Pinch Bars and Nylon Bushing.
- TEMPERATURE:** -50°C to 80°C.
- MATERIAL CERTIFICATION:** Certified chemical and physical test reports can be supplied.

#### SLEEVE DESIGN



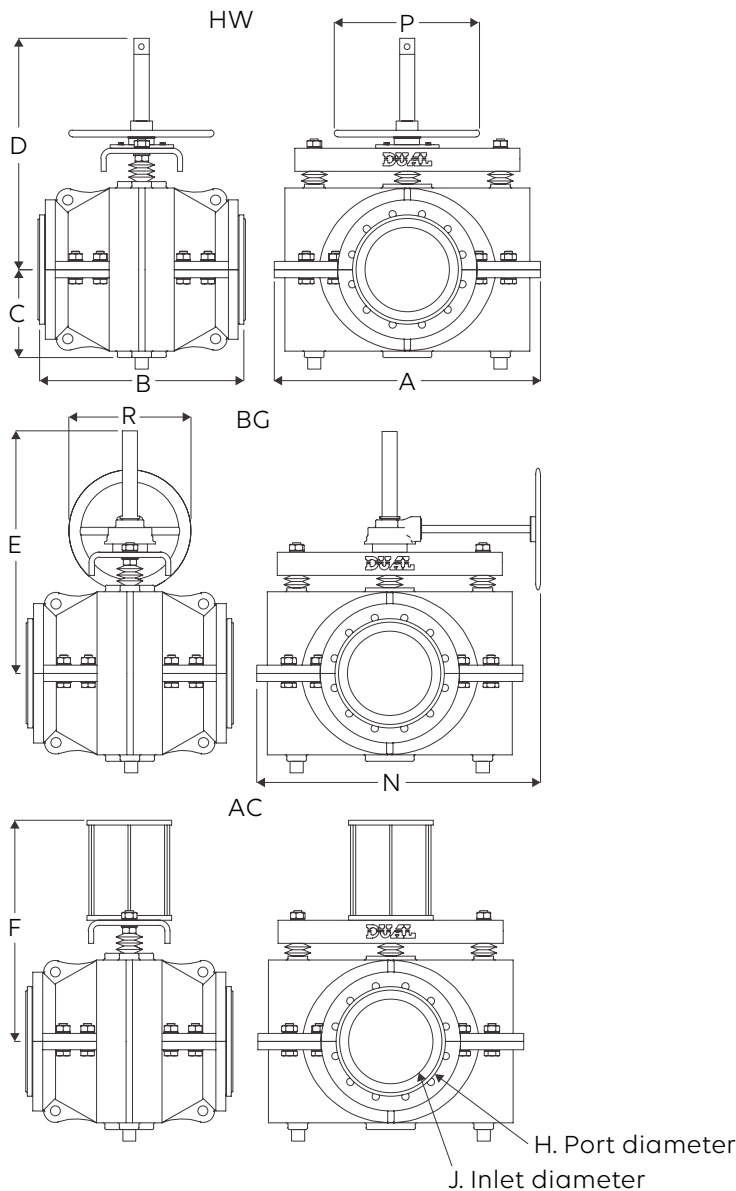

## ACTUATORS

All types of actuators can be fitted, electric, gearbox, hydraulic, pneumatic or handwheel.

## SLEEVE MATERIAL

Dual offers the following alternative sleeve materials, providing chemical and abrasive resistance to most media such as:

- Natural Red Rubber.
- Natural Black Rubber.
- Neoprene Rubber.
- Nitrile Rubber.
- EPDM Rubber.
- Reduced port sleeve for throttling applications.
- Urethane.

## APPLICATIONS

- Mining and mineral processing.
- Power generation.
- Sand and gravel.
- Chemical and soda ash.
- Pulp and paper.

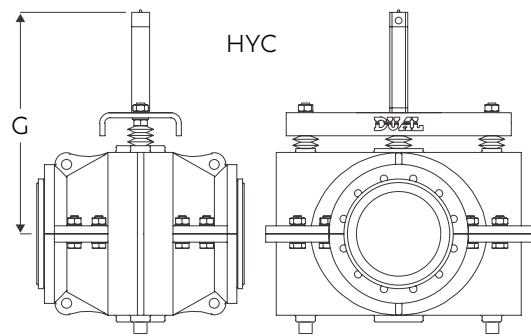

## DIMENSIONS AND WEIGHTS

VALVE SIZE (mm)	FACE TO FACE (B)															VALVE WEIGHT (kg)				
	A	ISO	ANSI	SABS	DIN	C	D	E	F	G	H	J	N	P	R	BG	AC	HVC	HW	
50	245	178	178	196	178	120	345	350	267	325	70	50	345	300	300	30	30	20	22	
80	300	203	200	262	203	155	366	370	346	390	100	80	400	300	300	50	50	30	30	
100	320	229	228	312	300	175	398	400	380	485	120	100	420	400	400	70	70	40	50	
125	345	254	250	365	325	210	489	500	399	525	135	125	445	400	400	80	80	70	70	
150	400	267	266	415	350	240	558	580	415	645	170	150	500	500	400	120	120	90	90	
200	520	457	400	530	400	295	726	750	501	900	220	200	620	500	400	220	220	170	140	
250	660	538	500	645	450	380	867	880	609	1040	270	250	760	500	400	280	280	190	160	
300	720	601	600	760	500	445	849	900	700	1720	320	300	830	600	400	380	380	230	220	
350	840	685	710	990	550	650	1024	1100	750	1930	370	350	940	600	400	400	400	350	330	
400	1080	762	810	1200	750	800	1406	1500	800	1470	420	400	1200	700	400	500	500	630	550	
450	1180	863	900	1350	810	900	1500	1600	850	1610	470	450	1280	700	400	600	600	680	730	
500	1280	914	1000	1500	880	1000	1600	1700	900	1760	520	500	1380	700	400	700	700	870	810	
600	1350	1051	1200	1500	1000	1200	1990	2100	1120	2040	620	600	1450	700	400	1000	1000	900	1000	

Contact Dual for larger sizes. Dimensions and weights are for guidance only - detailed dimension drawings available on request. All dimensions are in millimeters, unless stated.

## TROUBLE-FREE OPERATION

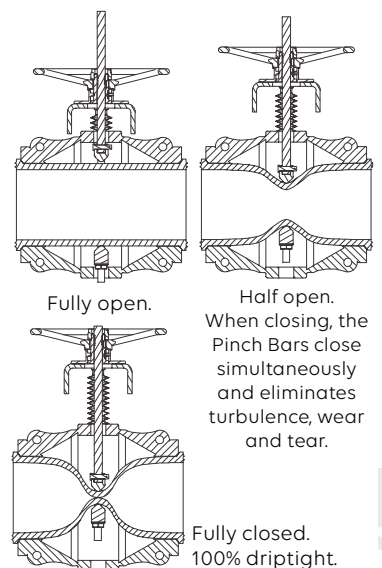

Fully open.

Half open. When closing, the Pinch Bars close simultaneously and eliminates turbulence, wear and tear.

Fully closed. 100% driptight.



CORPORATE HEADQUARTERS:  
166 ROTTERDAM ROAD  
(CNR ROTTERDAM ROAD & ANTWERP STREET)  
APEX BENONI GAUTENG SOUTH AFRICA

PO BOX 12520, BENORYN 1504  
TEL: +27 11 422 4326/7  
FAX: +27 11 421 7842  
EMAIL: SALES@DUALVALVES.COM

