

DUAL LINED KNIFE GATE VALVE



Zero discharge to atmosphere. Full round port design.

DUAL's Lined Knife Gate Valve is designed for full on/off abrasive and corrosive applications. The Urethane or Rubber lining is moulded throughout the body and chest area. The lining is flush with the bottom of the valve eliminating any pocket where material can collect. It has a full round port design with zero discharge to atmosphere.

FEATURES

- Perimeter sealing at 16 Bar.
- Smooth Bottom (No groove).
- No metal parts in contact with flowing slurry.
- Bubble tight shut off.
- No clogging bonnet to impede flow.
- External epoxy or powder coated.
- Easily adapted to fit most types of actuation.
- Low maintenance requirements.
- MSS-SP-81 Face-To-Face.
- Lock out & Switch mountings.
- Live - load packing gland.
- Full-port design & bi-directional.
- Lightweight material for easy handling.
- Minimised chest area & close tolerances preventing media from packing.
- Robust gate design reduces bending.
- Zero discharge to atmosphere.
- No pressure drop across valve.
- Fluorocarbon coated valve gate to reduce friction when stroked.
- PTFE blade wiper.
- Two piece body.
- Non-Rising spindle available.

PRODUCT SPECIFICATION

SIZE RANGE: 2" - 24" (50mm - 600mm).

VALVE TYPE: Slurry Knife Gate (MSS-SP-81 Face To Face).

BODY STYLE: Narrow Body (Wafer).

TEMPERATURE RANGE: 80°C.

PRESSURE RATING: Up to 240 Psi (16 Bar).

BODY MATERIAL: Cast Ductile Iron, 2 coat Epoxy Painted or Stainless Steel.

GATE MATERIAL: 17-4PH Stainless Steel, 316L Stainless Steel, 2205 Duplex Stainless Steel, 2507 Duplex Stainless Steel, C276 Hastelloy.

GATE / BLADE: Coated with Fluorocarbon coating.

SLEEVE MATERIAL: Poly-Urethane, Rubber or Lip Seal.

DUTY: Abrasive applications.

HYDRO-STATIC TEST: 1.5 Times the rated pressure.

TEST AND MATERIAL CERTIFICATES: Standard Quality Documents on request.

CERTIFICATES:

ACTUATION

- Electric
- Gearbox
- Hydraulic
- Pneumatic
- Handwheel

ACCESSORIES

- Limited Switches
- PTFE blade coating
- Various blade materials
- Gate safety guards
- Deflector cone

APPLICATIONS

- Mining and mineral processing.
- Power generation.
- Sand and gravel.
- Chemical and soda ash.
- Pulp and paper.
- Environmental and effluent.
- Dry feeds & Powders



Epoxy Coated with Lip-Seal



Soft Rubber Lined



Poly-Urethane Lined

HOW THE LINER WORKS

The Liner Seat is flush with the bottom of the port eliminating debris and slurry, allowing a leak free seal when closed. The liner also extends over the flange face essentially creating a gasket type seal when installed in the line, thus eliminating additional gaskets.

DIMENSIONS AND WEIGHTS

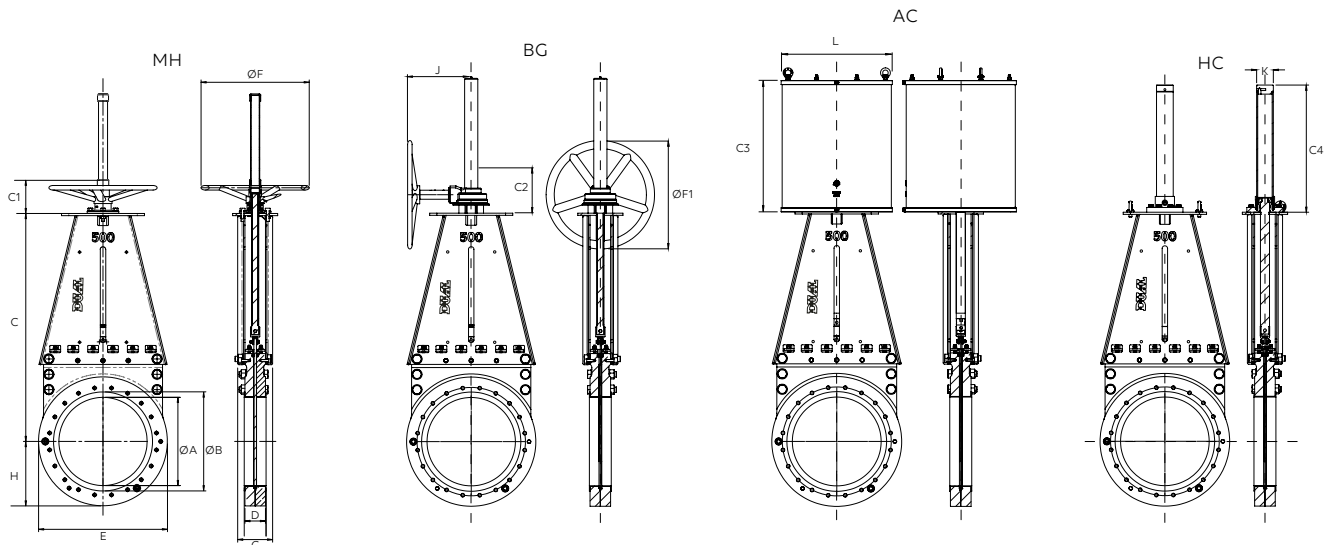

DIMENSIONS (mm)																	WEIGHT (kg)			
DN	ØA	ØB	C	C1	C2	C3	C4	D	E	ØF	ØF1	G	H	J	K	L	MH	BG	AC	HC
50	51	92	250	141	-	186	186	51	215	300	300	168	107	-	64	114	21	-	15	18
80	76	127	304	141	-	210	224	51	254	300	300	168	127	-	64	114	26	-	26	24
100	102	157	355	141	-	257	259	51	284	500	500	168	142	-	64	140	32	-	38	29
150	152	216	468	141	-	325	311	57	341	500	500	183	170	-	64	191	47	-	65	42
200	203	270	582	141	179	380	379	70	406	500	500	220	203	299	76	216	74	80	101	73
250	254	324	685	-	179	474	431	70	462	500	500	219	231	299	89	270	-	105	168	102
300	305	381	794	-	179	514	483	76	546	600	600	250	273	299	89	324	-	144	240	143
350	337	413	872	-	189	537	539	76	597	600	600	251	299	366	114	375	-	189	339	192
400	387	470	977	-	189	608	591	89	668	700	700	272	343	366	114	432	-	254	471	259
450	438	533	1108	-	189	676	656	89	723	700	700	302	362	366	127	483	-	363	649	382
500	489	584	1213	-	191	788	714	114	800	700	700	306	400	422	127	533	-	488	850	506
600	591	692	1448	-	221	950	836	114	943	700	700	368	472	460	165	635	-	757	1452	781
650	641	749	1576	-	221	1009	924	171	976	-	-	400	488	460	191	699	-	1006	1878	1065
700	692	800	1699	-	251	1061	976	181	1033	-	-	431	516	505	191	699	-	1205	2070	1256
750	743	857	1800	-	251	1136	1028	187	1097	-	-	461	548	505	191	756	-	1397	2625	1467

Contact Dual Valves for larger sizes. Dimensions and weights are for guidance only - detailed dimension drawings available on request. All dimensions are in millimeters, unless stated.



CORPORATE HEADQUARTERS:
166 ROTTERDAM ROAD
(CNR ROTTERDAM ROAD & ANTWERP STREET)
APEX BENONI GAUTENG SOUTH AFRICA

PO BOX 12520, BENORYN 1504
TEL: +27 11 422 4326/7
FAX: +27 11 421 7842
EMAIL: SALES@DUALVALVES.COM

