

DUAL FLANGED KNIFE GATE VALVE



DUAL's Flanged Knife Gate Valve is a true Bi-Directional gate valve. The rubber sleeves are designed to withstand the harsh abrasive duty within the mining and milling industry. Isolation is provided by the gate passing through the sleeves in such a manner that any solids that could potentially clog or jam the blade are purged out from between the sleeves to atmosphere, through the bottom of the valve housing.

PRODUCT SPECIFICATION

SIZE RANGE: 2" - 60" (50mm - 1500mm).

VALVE TYPE: Slurry Knife Gate.

BODY STYLE: Flanged.

TEMPERATURE RANGE: 176°F (80°C).

PRESSURE RATING: Up to 300 Psi (21 Bar).

BODY MATERIAL: Cast Ductile Iron, 2 coat epoxy painted.

GATE MATERIAL: 17-4PH Stainless Steel, 316L Stainless Steel, 2205 Duplex Stainless Steel, 2507 Duplex Stainless Steel, C276 Hastelloy.

GATE / BLADE: Coated with Fluorocarbon coating.

SLEEVE MATERIAL: Gum Rubber, High-temp EPDM, Neoprene, Nitrile, Butyl.

DUTY: Abrasive applications.

HYDRO-STATIC TEST: 1.5 Times the rated pressure.

TEST AND MATERIAL CERTIFICATES: Standard Quality Documents on request.

FEATURES

- Bi-Directional operation at 21 Bar.
- Zinc nickle plated hardware.
- Heavy duty stainless steel gate.
- CNC machined gate guide & body.
- Stuffing box with gland follower.
- Open body allows for purging.
- Low maintenance requirements.
- Manual lockout.
- Long-wearing, field replaceable sleeves, create a sealing surface.
- Two piece body, allows for easier rebuilds.
- Protective spindle covers & bellows.
- No seat cavity where solids can collect & prevent full gate closure.
- Lightweight design.
- Imperial & Metric flanged patterns.
- Two coat epoxy paint.
- Lubricant ports.
- Fluorocarbon coated gate to reduce friction & add wear life to sleeves.
- Universal tower frame.

ACTUATION

- Electric
- Gearbox
- Hydraulic
- Pneumatic
- Handwheel

ACCESSORIES

- Limited Switches
- PTFE blade coating
- Various blade materials
- Gate safety guards
- Deflector cone
- Bottom splash guard & drain plate.

APPLICATIONS

- Mining and mineral processing.
- Power generation.
- Sand and gravel.
- Chemical and soda ash.
- Pulp and paper.
- Environmental and effluent.
- Dry feeds & Powders



Dual Sleeve Isolation

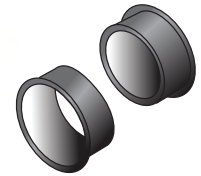

HOW THE SLEEVE WORKS

Designed specifically for heavy-duty applications, the sleeves are easily replaced in the field, prolonging valve working life. Sleeves provide 100% bubble tight seal and rely on the sleeves to seal. The sleeves are bi-directional and have an internal stiffening ring.

DIMENSIONS AND WEIGHTS

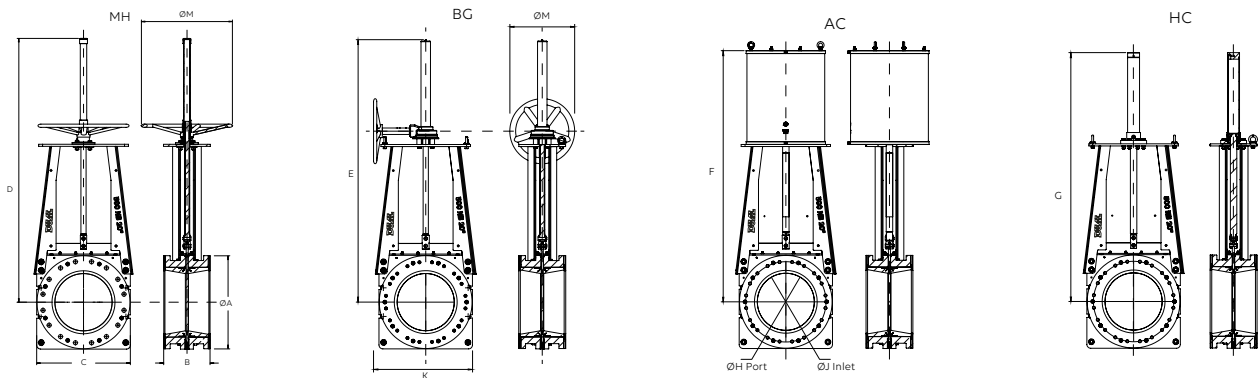

VALVE SIZE DN	DIMENSIONS (mm)			CENTERLINE TO TOP				ØH	ØJ	K	HANDWHEEL		WEIGHT (kg)			
	ØA*	B**	C	MH D	BG E	AC F	HC G				MH ØM	BG ØM	MH	BG	AC	HC
80	190	174	225	480	543	543	623	61	71	401	300	300	22	57	38	22
100	228	174	279	558	592	608	701	84	98	428	300	300	29	64	59	31
150	279	177	330	711	864	766	863	136	147	454	500	500	44	79	81	44
200	342	184	387	835	378	889	973	174	196	482	500	500	61	96	95	61
250	406	225	420	984	1082	1028	1123	230	249	594	500	500	89	124	140	79
300	482	257	533	-	1205	1155	1349	273	292	647	500	500	-	193	303	163
350	533	257	577	-	1354	1357	1468	317	336	670	600	600	-	203	326	187
400	596	279	615	-	1452	1528	1627	355	374	701	600	600	-	259	510	249
450	635	311	673	-	1695	1717	1746	377	425	770	700	700	-	396	603	430
500	698	358	720	-	1827	1866	1890	420	469	794	700	700	-	478	762	544
600	812	371	858	-	2189	2235	2276	538	584	882	700	700	-	990	997	635
650	869	365	933	-	-	-	2378	596	635	-	-	-	-	-	-	771
700	927	378	933	-	-	-	2378	596	635	-	-	-	-	-	-	816
750	984	395	1054	-	-	-	2697	679	736	-	-	-	-	-	-	975
800	1060	411	1054	-	-	-	2697	679	736	-	-	-	-	-	-	1089
900	1174	469	1225	-	-	-	3028	809	889	-	-	-	-	-	-	1724
1050	1346	536	1435	-	-	-	3700	971	1041	-	-	-	-	-	-	2585
1200	1511	536	1532	-	-	-	4019	1117	1187	-	-	-	-	-	-	3161
1350	1681	536	1708	-	-	-	4391	1244	1314	-	-	-	-	-	-	3754
1500	1854	536	1955	-	-	-	4781	1451	1511	-	-	-	-	-	-	4309

Contact Dual Valves for larger sizes. Dimensions and weights are for guidance only - detailed dimension drawings available on request. All dimensions are in millimeters, unless stated.



CORPORATE HEADQUARTERS:
166 ROTTERDAM ROAD
(CNR ROTTERDAM ROAD & ANTWERP STREET)
APEX BENONI GAUTENG SOUTH AFRICA

PO BOX 12520, BENORYN 1504
TEL: +27 11 422 4326/7
FAX: +27 11 421 7842
EMAIL: SALES@DUALVALVES.COM

