

DUAL FLANGED HIGH PRESSURE KNIFE GATE VALVE



Premium materials are supplied standard on all valves.

FEATURES

- Bi-Directional operation at 51 Bar.
- Zinc nickle plated hardware.
- Heavy duty stainless steel gate.
- CNC machined gate guide & body.
- Manual lockout.
- Stuffing box with gland follower.
- Double seat design for heavy duty slurry service.
- Low maintenance requirements.
- 100% bubble tight shut off.
- Imperial & Metric flanged patterns.
- Protective spindle cover & bellows.
- Full port & bi-directional.
- Flush ports in valve body.
- Open body allows for purging.
- Two coat epoxy paint.
- Lubrication ports.
- Fluorocarbon coated gate to reduce friction & increase wear life on sleeves.
- Two piece body allows for easier rebuilds.
- Universal tower frame.

DUAL's Flanged High Pressure Knife Gate Valve is a true bi-directional knife gate valve. Its rubber sleeves are designed to seal and withstand the harsh abrasive duty inherent in mining & milling facilities, isolation is provided by the gate passing through the sleeve in such a manner that any solids that could potentially clog or jam the blade are purged out from between the sleeves to atmosphere, through the bottom of the valve housing.

PRODUCT SPECIFICATION

SIZE RANGE: 3" - 36" (80mm - 900mm).

BODY: Full Flanged. Slurry Knife Gate (High pressure).

TEMPERATURE RANGE: 176°F (80°C).

RETAINER FLANGES: Rubber covered Carbon Steel Flanges (80mm through to 900mm).

PRESSURE RATING: Up to 740 Psi (51 Bar).

BODY MATERIAL: Cast Ductile Iron, 2 coat epoxy painted.

GATE MATERIAL: 17-4PH Stainless Steel, 316L Stainless Steel, 2205 Duplex Stainless Steel, 2507 Duplex Stainless Steel, C276 Hastelloy.

GATE / BLADE: Coated with fluorocarbon coating.

SLEEVE MATERIAL (replaceable): Gum Rubber, high-temp EPDM, Neoprene, Nitrile, Chlorobutyl.

DUTY: Medium to Heavy abrasive applications.

HYDRO-STATIC TEST: 1.5 Times the rated pressure.

TEST AND MATERIAL CERTIFICATES: Standard Quality Documents on request.

CERTIFICATES:

ACTUATION

- Electric
- Gearbox
- Hydraulic
- Pneumatic
- Handwheel

ACCESSORIES

- Limited Switches
- PTFE blade coating
- Various blade materials
- Gate safety guards
- Deflector cone
- Bottom splash guard & drain plate

APPLICATIONS

- Mining and mineral processing.
- Power generation.
- Sand and gravel.
- Chemical and soda ash.
- Pulp and paper.
- Environmental and effluent.

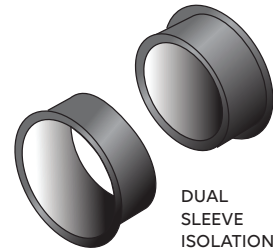

DUAL SLEEVE ISOLATION



ADVANTAGES OF THE RUBBER SLEEVES

Designed specifically for heavy-duty slurry applications, the sleeves are easily replaced in the field, prolonging valve working life. Sleeves provide a 100% bubble tight seal and rely on the pressure between the sleeves to seal. The sleeves are bi-directional and have an internal stiffening ring.

DIMENSIONS AND WEIGHTS

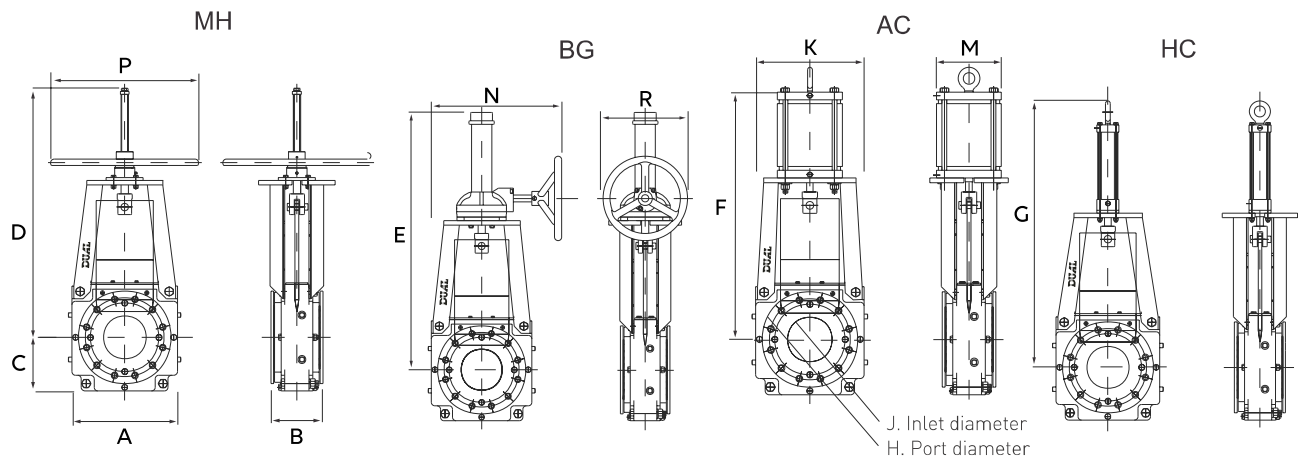

DIMENSIONS (mm)															VALVE WEIGHT (kg)			
VALVE SIZES DN	A	B	C	D	E	F	G	H	J	K	M	N	P	R	MH	BG	AC	HC
80	266	175	133	520	579	408	595	61	71	268	176	422	300	300	22	57	38	22
100	298	176	152	692	718	663	768	85	98	320	232	449	300	300	29	64	59	31
150	362	184	184	853	928	772	928	146	148	374	262	476	500	500	44	79	81	44
200	425	184	215	1004	1033	994	1099	186	199	444	340	606	500	500	61	96	95	61
250	510	226	254	1207	1207	1197	1289	231	248	432	431	650	500	500	89	124	140	79
300	571	258	279	1360	1360	1300	1417	273	292	431	431	650	500	500	100	193	303	163
350	749	259	352	1544	1544	1519	1468	317	337	431	431	650	600	600	180	203	326	187
400	825	278	393	1690	1690	1643	1627	362	374	482	479	675	600	600	200	259	510	249
450	882	321	419	1797	1797	1733	1924	381	431	431	431	650	700	700	350	396	603	430
500	946	366	450	2036	2036	1993	2111	420	469	584	534	780	700	700	400	478	762	544
600	1130	369	546	2269	2269	2269	2336	538	576	558	481	713	-	-	850	990	997	635
750	1358	413	660	-	-	-	2860	679	736	553	509	-	-	-	-	-	-	850
900	1524	471	762	-	-	-	3327	809	889	635	479	-	-	-	-	-	-	1000

Contact Dual Valves for larger sizes. Dimensions and weights are for guidance only - detailed dimension drawings available on request. All dimensions are in millimeters, unless stated.



CORPORATE HEADQUARTERS:
166 ROTTERDAM ROAD
(CNR ROTTERDAM ROAD & ANTWERP STREET)
APEX BENONI GAUTENG SOUTH AFRICA

PO BOX 12520, BENORYN 1504
TEL: +27 11 422 4326/7
FAX: +27 11 421 7842
EMAIL: SALES@DUALVALVES.COM

