

DUAL DASHLEY DOUBLE BALL CHECK VALVE



FEATURES

- As the elastomer covered ball rises or falls it rotates with the flow.
- This ensures that the valve self cleans and permits it to open and close reliably even under severe conditions of slurry build up.
- Minimal pressure drop.
- Optional handwheel for isolation.

350MM DASHLEY WITH HANDWHEEL ISOLATION



DUAL's Dashley valve operates on the discharge side of two pumps in parallel. Both pumps can run simultaneously or independently. When both or one pump is switched off, the ball will automatically drop back stopping the back flow to the pump.

PRODUCT SPECIFICATION

- The body is carbon steel (fabricated).
- The valve body can be lined in Natural Black Rubber, Neoprene, Hypalon, EPDM, Ceramic or Urethane.
- Seats are replaceable and can be made of any material requested by the client.
- Balls are replaceable and are made of urethane or rubber.
- Shouldered end connections for victaulic couplings (if required).
- Valve flanged to customer specification.
- Flushing port in ball bodies.
- Lifting Lugs.
- Balls can be replaced or inspected from top ball cover.
- Different mounting brackets can be fitted to suit application.
- **Pressure Rating:** 10, 16, 25 Bar.

REPLACEABLE BALLS AND SEALS



YOU CAN RUN BOTH PUMPS SIMULTANEOUSLY OR ONE AT A TIME

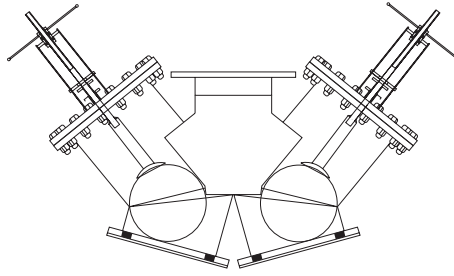

Both Pumps Isolated.
With Handwheels.
No Flow.

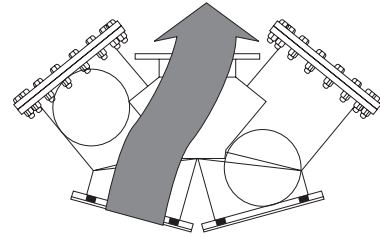

Flow from left pump.

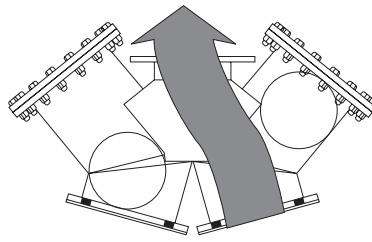

Flow from right pump.

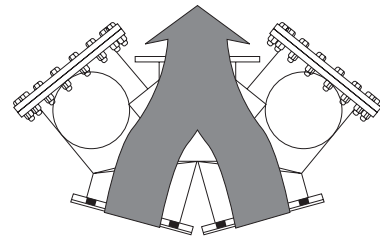

Flow from both pumps.

APPLICATIONS

- All slurry applications requiring trouble free pump changeover.
- Particularly suited for mill cyclone feed pumps.

DIMENSIONS AND WEIGHTS

PART	DESCRIPTION
1	Body Carbon Steel/Stainless Steel
2	Body Seat Urethane Or Rubber
3	Ball Urethane Or Rubber
4	Flushing Port Carbon Steel/Stainless Steel
5	Lifting Lugs Carbon Steel/Stainless Steel
6	Ball Body Cover Carbon Steel/Stainless Steel
7	Body Lining Rubber, Urethane Or Ceramic

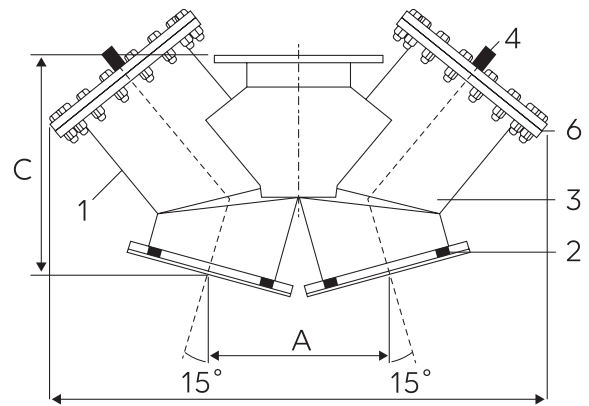

VALVE SIZE				A	B	C	D		WEIGHT		
INCHES	mm	INCHES	mm	INCHES	mm	INCHES	mm	INCHES	mm	LBS.	kg
4	100	9.52	238	10.4	260	14.00	355.6	27.20	680	75	34
6	150	12.00	300	14.00	350	16.75	425.5	38.40	960	155	70
8	200	13.96	349	16.96	424	20.38	517.7	41.60	1040	300	136
10	250	16.56	414	19.60	490	22.69	576.3	53.60	1340	500	227
12	300	19.48	487	22.84	571	26.75	679.5	61.60	1540	640	291
14	350	18.16	454	24.16	604	28.63	727.7	68.00	1700	775	352
16	400	24.68	617	26.92	673	32.63	828.8	80.00	2000	1000	454
18	450	26.16	654	30.24	756	36.75	933.5	80.00	2000	1550	704
20	500	28.68	717	34.08	852	39.44	1001.8	84.00	2100	1950	885
24	600	AND ABOVE ON APPLICATION									

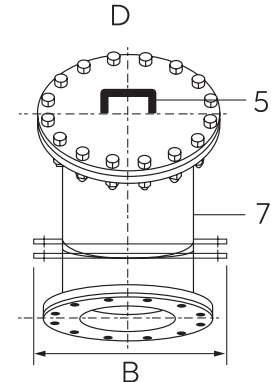

Dimensions and weights are for guidance only - detailed dimension drawings available on request.



CORPORATE HEADQUARTERS:
166 ROTTERDAM ROAD
(CNR ROTTERDAM ROAD & ANTWERP STREET)
APEX BENONI GAUTENG SOUTH AFRICA

PO BOX 12520, BENORYN 1504
TEL: +27 11 422 4326/7
FAX: +27 11 421 7842
EMAIL: SALES@DUALVALVES.COM